



# INSTRUCTIONS

-J04164

REV. 2007-06-06

## SCREAMIN' EAGLE® STAGE 1 KIT FOR EFI MODELS

### GENERAL

#### Kit Number

29773-02C

#### Models

Fits 2004-2007 EFI Dyna, 2001-later EFI Softail, 2002-2007 EFI Touring (except 2006 FLHTCUSE, 2007 FLHTCUSE2) model motorcycles. Also fits 2008 Dyna models with appropriate accessory covers.

#### Additional Parts Required

Proper installation of this kit requires the use of Digital Technician™ at a Harley-Davidson dealer.

This kit requires the separate purchase of Air Cleaner/Degreaser (99883-88T) which is available from a Harley-Davidson dealer.

### ⚠ WARNING

**The rider's safety depends upon the correct installation of this kit. Use the appropriate service manual procedures. If the procedure is not within your capabilities or you do not have the correct tools, have a Harley-Davidson dealer perform the installation. Improper installation of this kit could result in death or serious injury. (00333a)**

#### NOTE

*This instruction sheet references Service Manual information. A Service Manual for your model motorcycle is required for this installation and is available from a Harley-Davidson dealer.*

#### Kit Contents

See Figure 1 and Table 1.

#### NOTES

*Installation of this kit by an authorized Harley-Davidson dealer will not impact your limited vehicle warranty.*

*This Stage 1 kit is intended for High Performance applications only. This engine related performance part is legal for sale or use in California on pollution controlled motor vehicles. Engine related performance parts are intended for the experienced rider only.*

*The Product Information Label contained in this kit is a requirement of the California Air Resource Board (CARB) emission regulation, for pre-2008 models. Place the label on the right side of the frame directly beneath the VIN sticker. This label is not required outside the state of California, or for 2008 models within the state of California.*

*The air cleaner contained in this kit is designed to perform with this kit only. Any other combination of components is not confirmed to be legal for street use.*

### REMOVAL

### ⚠ WARNING

**To prevent accidental vehicle start-up, which could cause death or serious injury, disconnect battery cables (negative (-) cable first) before proceeding. (00307a)**

### ⚠ WARNING

**Disconnect negative (-) battery cable first. If positive (+) cable should contact ground with negative (-) cable connected, the resulting sparks can cause a battery explosion, which could result in death or serious injury. (00049a)**

- 2004-2005 Dyna, 2001-2006 Softail, 2002-2005 Touring:
  - Remove seat according to the instructions in the Service Manual.
  - Disconnect battery cables, negative (-) cable first.
- 2006-later Dyna, 2007-later Softail, 2006-2007 Touring:
  - Remove Maxi® fuse. Refer to MAXI FUSE REMOVAL in Service Manual.
- Remove existing air cleaner backplate. Refer to AIR CLEANER: EFI, REMOVAL in Service Manual. Save stock air cleaner cover, button head screw that secures cover, and two breather screws removed from backplate. Discard remaining parts.

### INSTALLATION

#### Install Air Cleaner

### ⚠ WARNING

**The element in this kit is specifically designed for use with the OE (original equipment) cover. Using this kit with an air cleaner cover other than the OE cover could lead to failure of the element faceplate. The kit may be used in conjunction with other H-D accessory covers provided the appropriate adapter recommended in those kits is used. If the element faceplate fails the cover could detach possibly distracting the rider which could result in death or serious injury. (00400b)**

#### NOTE

*When servicing the air cleaner, apply Loctite® 243 (blue) 99642-97 to threads of all fasteners.*

- 2007-later models only: Clean lower area of induction module side of backplate. Use a mixture of 50 to 70% isopropyl alcohol and 30 to 50% distilled water. Allow to dry thoroughly.

- Orient adhesive backed clip (8) with opening upwards, and affix in 6 o'clock position. Clamp wire harness previously removed from OE backplate.
- See Figure 1. Install two O-rings (1) from kit in grooves around breather screw holes on induction module side of backplate assembly (2).
  - Align flat edge of gasket (3) with the molded tab, and install on induction module side of backplate.
  - Insert breather screws (A) through the backplate.
  - Apply Loctite 243 (blue) to breather screw threads and mating tapped holes in cylinder head.
  - Thread screws into cylinder head but do not tighten.
  - Thread air cleaner mounting studs (4) all the way through the backplate (2) and gasket (3) until the screw threads are captured in induction module. Do not tighten completely at this time.
  - Alternately tighten two breather screws (A) to 120-144 **in-lbs** (13.6-16.3 Nm).
  - Press breather plugs (5) into breather screw cavities, aligning tubes with recesses in backplate.
  - Tighten three air cleaner studs (4) to 55-60 **in-lbs** (6.2-6.8 Nm).

### Install Air Cleaner Element and Cover

#### NOTES

*This is a dry air filter. Do not apply oil to the filter element.*

*Whenever the air cleaner cover is installed, apply Loctite 243 (blue) to the air cleaner cover screw.*

- See Figure 1. Secure air filter element (7) to air cleaner mounting studs (4) using screws (6). Tighten screws to 55-60 **in-lbs** (6.2-6.8 Nm).
- Apply Loctite 243 (blue) to threads of air cleaner cover screw (C). Secure air cleaner cover (B) to air filter element (7) with screw.
- Align air cleaner cover horizontally for best appearance, then tighten screw securely. Tighten to 36-60 **in-lbs** (4.1-6.8 Nm).

### Final Assembly

#### WARNING

**Connect positive (+) battery cable first. If positive (+) cable should contact ground with negative (-) cable connected, the resulting sparks can cause a battery explosion, which could result in death or serious injury. (00068a)**

- 2004-2005 Dyna, 2001-2006 Softail, 2002-2005 Touring:
  - Connect battery cables, positive (+) cable first.
  - Install seat according to the instructions in the Service Manual.
- 2006-2008 Dyna, 2007-later Softail, 2006-2007 Touring:
  - Install Maxi fuse. Refer to MAXI FUSE INSTALLATION in Service Manual.

#### WARNING

**After installing seat, pull upward on seat to be sure it is locked in position. While riding, a loose seat can shift causing loss of control, which could result in death or serious injury. (00070b)**

### Recalibrate ECM

#### NOTICE

**You must recalibrate the ECM when installing this kit. Failure to properly recalibrate the ECM can result in severe engine damage. (00399b)**

Download the new ECM calibration using the Digital Technician™ at a Harley-Davidson dealer.

## MAINTENANCE

### Air Cleaner Element Maintenance

#### NOTES

*This is a dry air filter. Do not apply oil to the filter element.*

*When servicing the air cleaner, apply Loctite 243 (blue) to threads of all fasteners.*

- See Figure 1. Remove air cleaner cover (B) and inspect the filter element (7) every 5000 mi (8000 km), or more often under dusty conditions.
- Clean filter element as follows:
  - Remove and wash element by immersing it, on edge, in a shallow pan containing enough Air Cleaner/Degreaser to cover *no more than 3/4* the depth of the filter pleats. *Do not let dirty solution get inside the element.* Carefully "roll" the element in the solution around its perimeter until the entire outer surface of the filter pleats has been soaked.
  - Remove filter element from cleaner/degreaser and allow five minutes for the cleaner to dissolve the dirt.
  - From the inside out, rinse the element with cold water. Shake off excess water, and allow the element to air dry. *Do not dry with compressed air.*
- Install air cleaner element and cover.

# SERVICE PARTS

is03201a

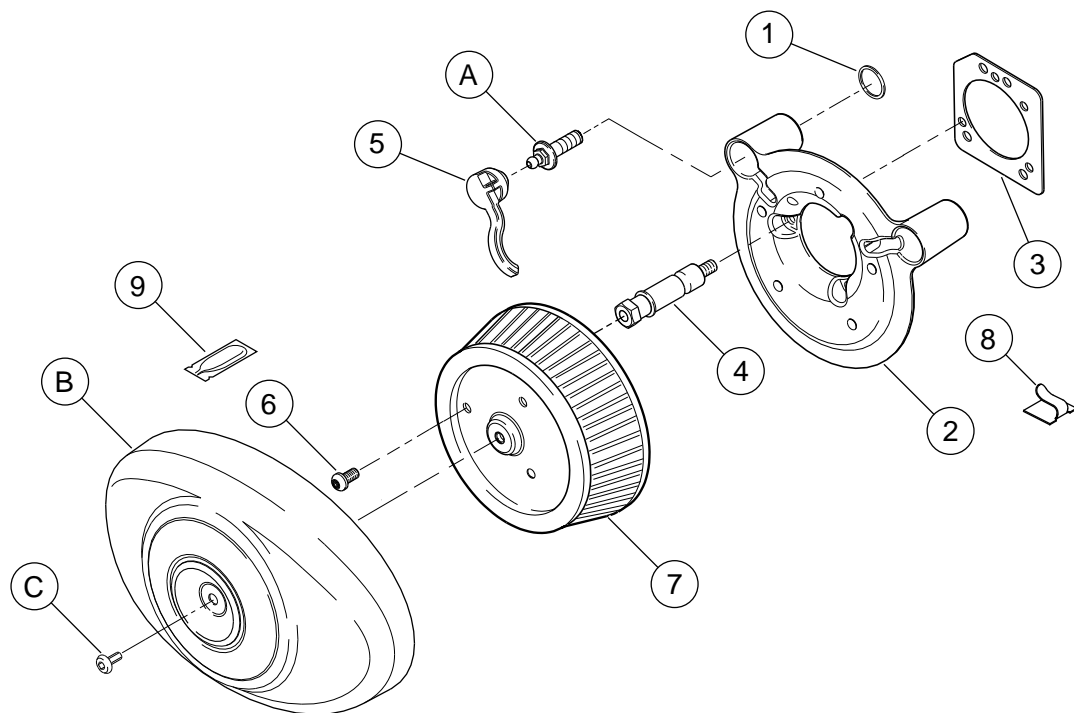

**Figure 1. Service Parts: Screamin' Eagle Stage 1 Kit**

**Table 1. Service Parts: Screamin' Eagle Stage 1 Kit**

Item	Description (Quantity)	Part Number
1	O-ring (2)	11292
2	Backplate assembly	29478-05A
3	Gasket, backplate	29583-01A
4	Stud, air cleaner (3)	29447-99A
5	Plug, breather (2)	29557-05
6	Screw, air cleaner element (3)	3938
7	Filter element	29442-99D
8	Clip, adhesive	10102
9	Loctite 243 (Blue) 0.5 ml packet	Not Sold Separately
10	Product information label (Not Shown)	Not Sold Separately
<b>Items mentioned in text, but not included in kit:</b>		
A	Breather screw (2)	
B	Air cleaner cover	
C	Screw	